



Scholars Research Library

Archives of Physics Research, 2010, 1 (2):118-128
(<http://scholarsresearchlibrary.com/archive.html>)



Assessment of shallow aquiferous units and their coefficients of anisotropy in the coastal plain sands of Southern Ukanafun local government area, Akwa Ibom State, Southern Nigeria

N.J George^a, V.I Obianwu^b, A.E Akpan^c and I.B Obot^d

^a Department of Science and Technology, Akwa Ibom State Polytechnic, IKot Asurua, Akwa Ibom State Nigeria

^{b&c} Department of physics, University of Calabar Calabar, Nigeria

^d Department of Chemistry, University of Uyo, Uyo Akwa Ibom State, Nigeria

Abstract

The aquiferous sandy units of the Continental Plain sands built on silicic deposits of high energy Niger Delta were investigated for both the primary and secondary parameters in southern Ukanafun Local Government Area of Akwa Ibom State, southern Nigeria. The investigation was done using electrical resistivity method employing vertical electrical sounding method. Results were examined by correlating the analyzed data with local geology, bore well data in the study area and other available constraints of striking geologic evidences were juxtaposed with inferred geoelectric data interpretation as caveats towards improving the reliability and validity of the interpretation. The results show that aquiferous sandy units assessed within the maximum current electrode separations were fairly isotropic as the transverse resistivity for each layer shows little or no variations with respect to the longitudinal resistivity. This was reflected by each layer having coefficient of anisotropy or pseudo-anisotropy as approximately 1.

Key words: Aquiferous units, coefficient of anisotropy, secondary parameters, Continental Plain sand, Ukanafun and isotropy.

INTRODUCTION

The groundwater occurrence in geological contacts between two geologic units has given ample scope for exploring it in Southern Ukanafun Local Government Area of Akwa Ibom State. The presence of thinly impermeable clayed layers observed in lithologic data over thickly permeable sandy layers such as sandstone, coarse sand, medium grained sand and fine sand has energized the transverse and longitudinal recharges of aquifers from surface and subsurface sources [1]. In such areas, the contacts between the permeable and thinly impermeable layers have become the loci for recharge of groundwater. Hence, locating such contacts and characterizing the aquifers assume significance in groundwater exploration [2].

No detailed geophysical surveys were carried out earlier in the area to locate groundwater reserve or its potential except the regional magnetic and gravity surveys which were carried out by the Nigerian Geological Survey Agency at low frequency and long wavelength to map the deeper sources far below the shallow layers where groundwater is trapped and the information from the logged boreholes in the area [3].

Thus, delineating the lithologic units that are favourable to groundwater accumulation and delineating secondary parameters such as longitudinal unit conductance (S_t), transverse unit resistance (T_t) longitudinal resistivity (ρ_L), transverse resistivity (ρ_t) and coefficient of anisotropy (λ) that are complementary to the fundamental parameters which are resistivities and thicknesses was carried out.

Accordingly, an investigation employing vertical electrical sounding method along a selected traverse was carried out. The acquired data were interpreted and correlated with available geology and other information including bore well data which serve as reliable caveats in analyzing geophysical data. Surficial aquifers within the sediment have been investigated.

Location and geology of the study area

The locations selected for the investigation cover seven villages in Southern Ukanafun Local Government Area, Akwa Ibom State, Southern Nigeria (Fig 1). Climatically, the study area enjoys an equatorial climate consisting mainly of two major seasons: rainy season (March-October) and dry season (November-February) [2]. The mean monthly rainfall during rainy season is about 135mm and this falls to 65mm during dry season [2].

The monthly mean temperature varies from annual mean temperature by 55 °C- 65 °C and the maximum daily mean temperature is between 28 °C - 30 °C [3]. The geographic positioning system (G.P.S) coordinate shows that the area lies between latitude 4° 55¹ N and 5° 00¹ N and longitude 7° 30¹ E and longitude 7° 40¹ E in Akwa Ibom state, south eastern Nigeria.

Geologically, the study area is Recent to Tertiary sediments belonging to the Benin formation of the Nigeria Delta (Fig 2). The formation comprises continental sand and gravel deposited in an upper deltaic plain environment [4]. The grain sizes range from coarse to fine in texture and are poorly sorted [5]. They are also thick and friable with minor intercalations of clay, silts and sandstones in the mapped area [5]. The alternative sequence builds up multiple aquifer systems with various thicknesses [6-10].

The mapped area which sits on a relatively flat terrain is drained by the Kwa Ibo River [11]

MATERIALS AND METHODS

The work was carried out using SAS 1000 model of ABEM terrameter and its accessories. The equipment was used with strict adherence to the precautions available in the instrument operational manual.

At the field, vertical electrical sounding (VES) method employing Schlumberger electrode configuration was used to obtain eighteen soundings along a selected profile that cuts across the seven villages shown in Fig 1. The maximum current electrode spread ranged between 600m to 800m depending on the accessibility of the area, human settlements and other infrastructural masts which posed some barriers to the profile taken. The sounding points were 400m apart. With Schlumberger electrode configuration shown in Fig 3, earth resistance were measured in

ohm and converted to resistivity in ohm-meter based on the geometric factor of the current and potential electrodes.

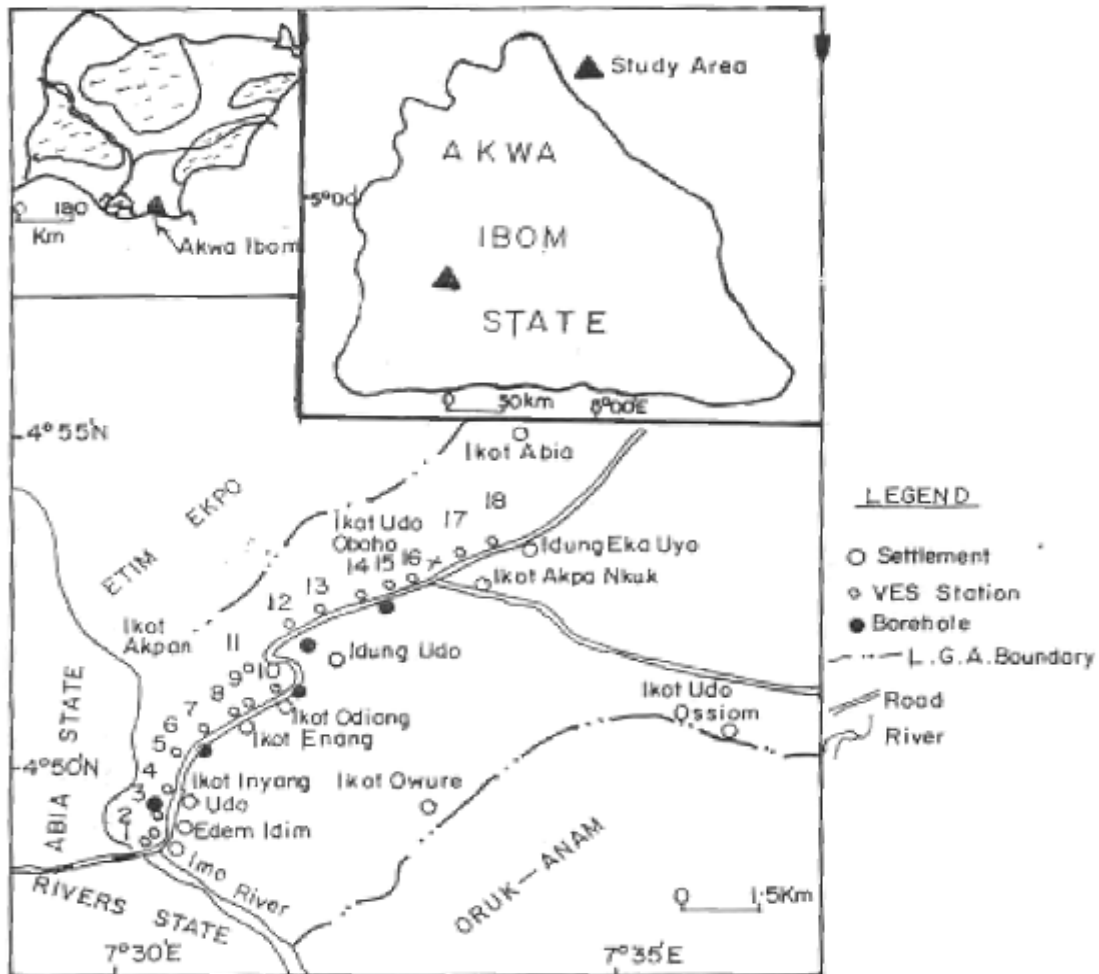

Fig. 1: Location map of southern Ukanafun local Government Area of Akwa Ibom State VES and Boreholes

Data analysis began at the field as the measured resistivity were smoothed by manually plotting the apparent resistivity values against the layer half current electrode separations. The smoothed data (resistivities at various half-current electrode separations) were fed into forward modeling programme developed by Zohdy and Bisdorf [2]. The results (resistivities and depths) were post fed into the inverse modeling programme developed by Hemkler [13]. The final modelled results (resistivities and depth) were obtained and the thickness were evaluated from top to the bottom of the maximum electrodes current penetration. Resistivities and thicknesses obtained served as the primary parameters that were then used to determine the secondary parameters that characterized the vertical and horizontal dimension of the approximate layers that currents penetrated.

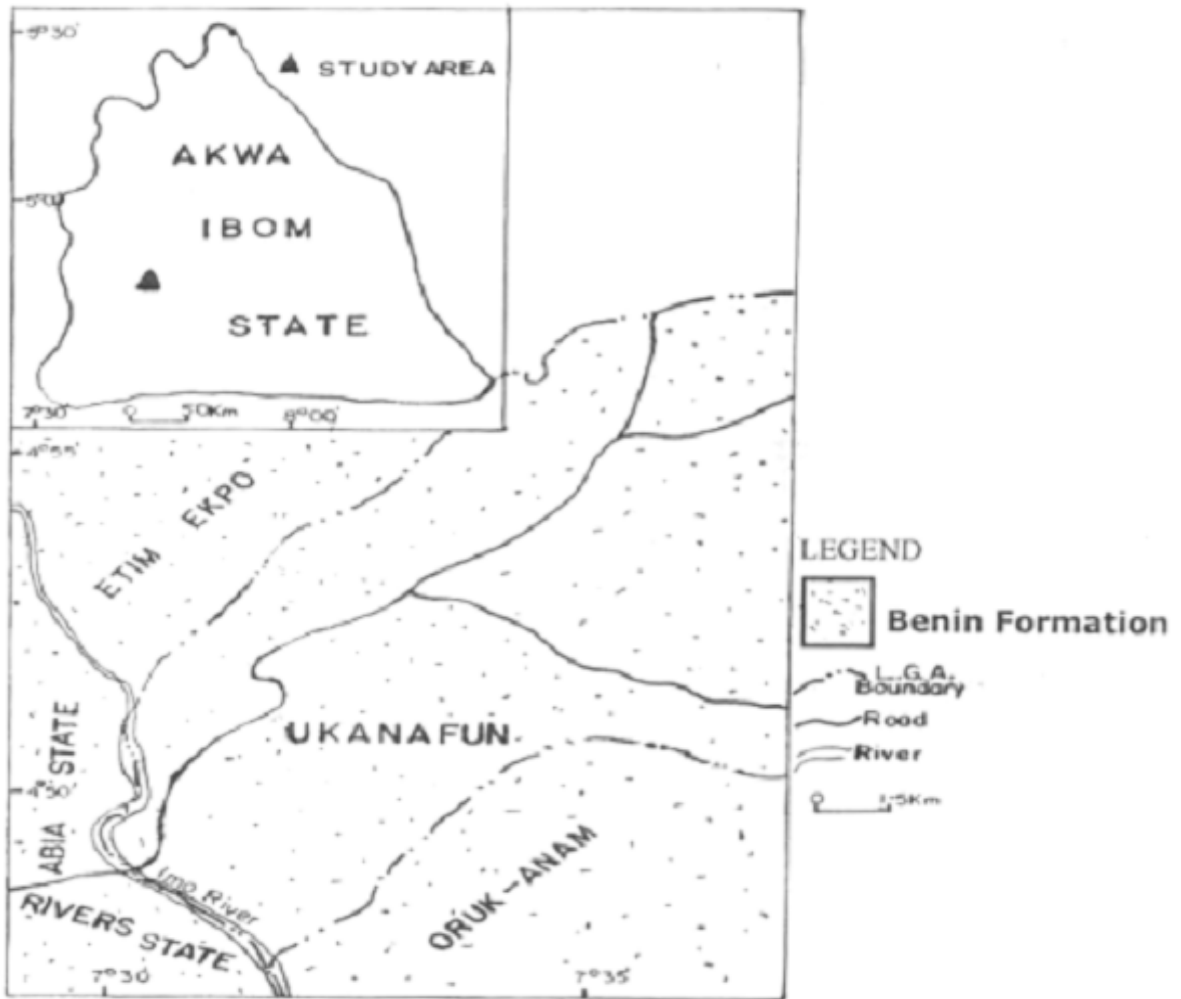

Fig. 2: Geographic map of southern Ukanafun and environs
(Adapted from the mineral occurrence map of Akwa Ibom State. Corporate Author, 1993)

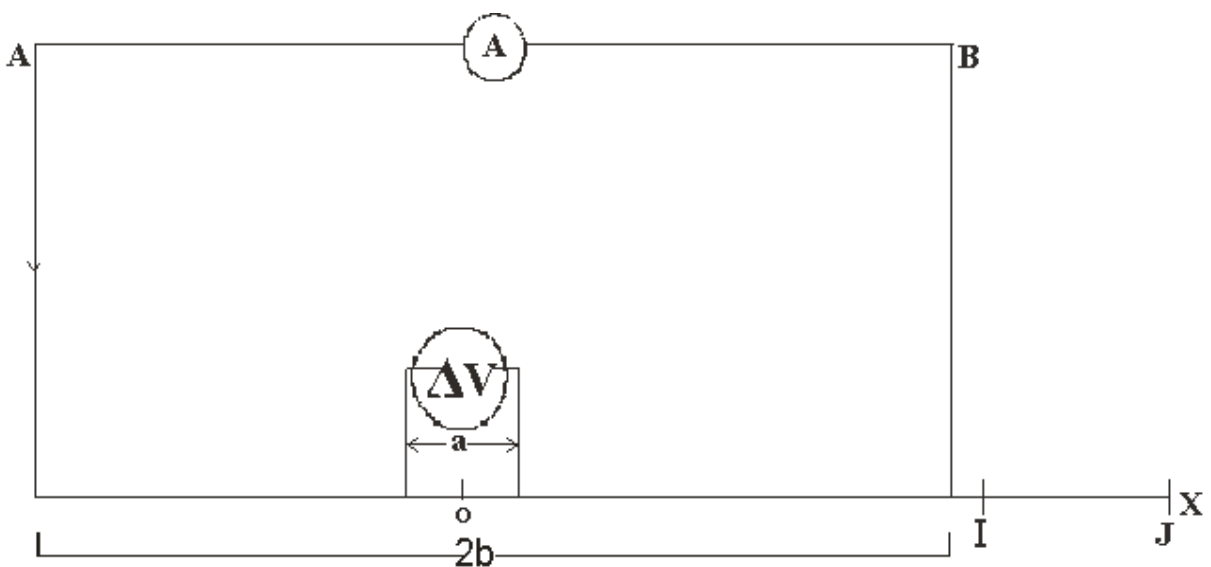

Fig. 3: Schlumberger electrode array

Data analysis began at the field as the measured resistivity were smoothed by manually plotting the apparent resistivity values against the layer half current electrode separations. The smoothed data (resistivities at various half-current electrode separations) were fed into forward modeling programme developed by Zohdy and Bisdorf [2]. The results (resistivities and depths) were post fed into the inverse modeling programme developed by Hemkler [13]. The final modelled results (resistivities and depth) were obtained and the thickness were evaluated from top to the bottom of the maximum electrodes current penetration. Resistivities and thicknesses obtained served as the primary parameters that were then used to determine the secondary parameters that characterized the vertical and horizontal dimension of the approximate layers that currents penetrated.

Figure 4 is a modified layer that current penetrated and is used to show how transverse resistance and longitudinal conductance are derived in a transverse and longitudinal section of the column of unit square cross-sectional area.

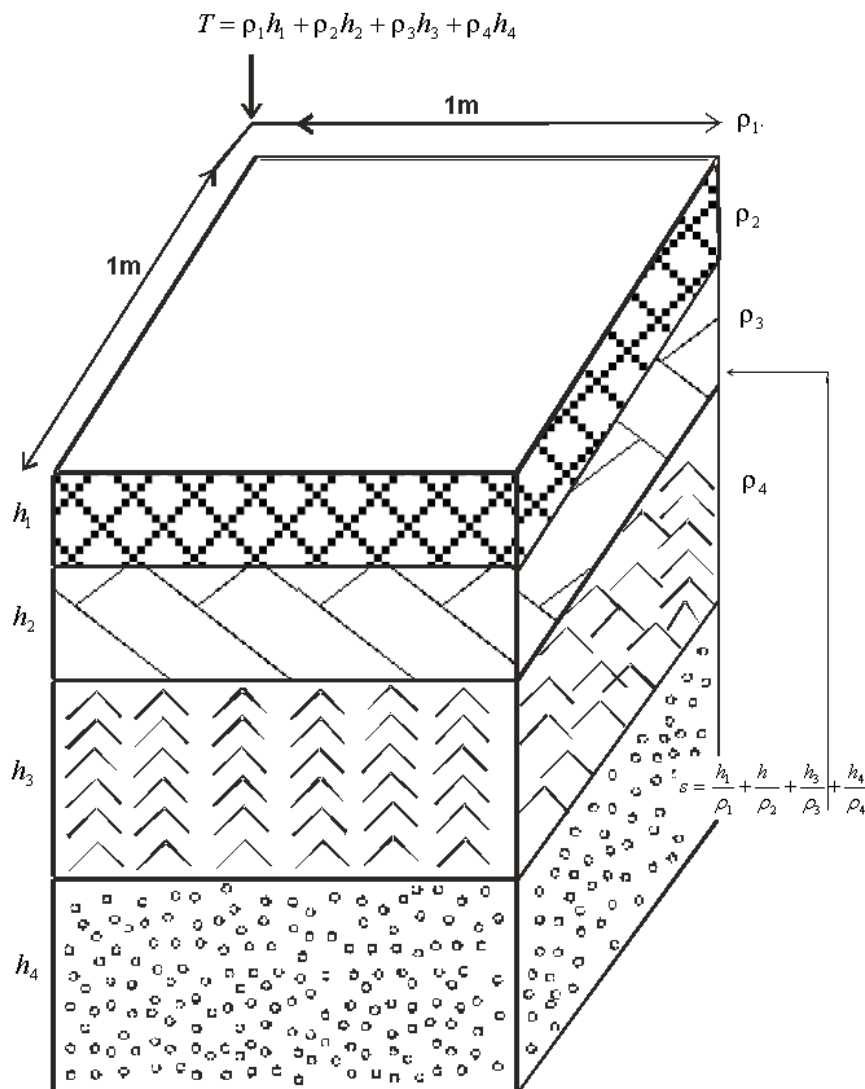

Fig 4: Column of layers of square cross sectional area defining primary geoelectric parameters of the geoelectric column

A geologic section differs from a geoelectric section when the boundaries between geologic layers do not coincide with the boundaries between layers characterized by different resistivities [14]. Thus, the electric boundaries separating layers of different resistivities may or may not coincide with boundaries separation layers of different geologic age or different lithologic compositions. In the opposite situation, layers of different lithologies or ages or both, may have the same resistivities and thus form a single geologic layer. In this study, the geologic layer is described by two fundamental parameters: its resistivity ρ_i and its thickness h_i , where the subscript i indicates the position of the layer in the column section ($i = 1$ for the uppermost layer). Other geoelectric parameter (secondary) are derived from it resistivity and thickness.

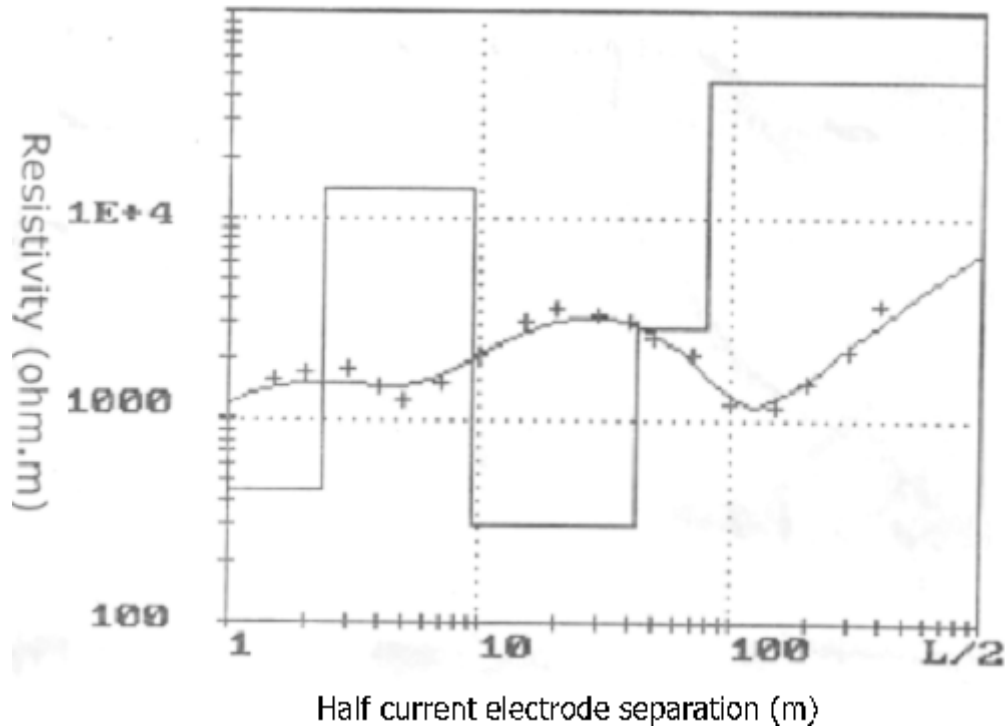

Fig. 5: A typical model curve (AKHA, KHA and HKHA curve type) from VES 18 of the study area

These are:

$$\text{Longitudinal unit conductance, } S_i = \frac{h_i}{\rho_i} \tag{1}$$

$$\text{Transverse unit resistance, } T_i = h_i \rho_i \tag{2}$$

$$\text{Longitudinal resistivity, } P_L = \frac{h_i}{s_i} \tag{3}$$

$$\text{Transverse resistivity, } \rho_t = \frac{T_i}{h_i} \tag{4}$$

$$\text{Anisotropy, } \lambda = \left(\frac{\rho_t}{\rho_L} \right)^{1/2} \tag{5}$$

For anisotropy layer $\rho_t = \rho_L$ and $\lambda = 1$ [14].

These secondary geoelectric parameters are particularly important when they are used to describe a geoelectric section consisting of several layers.

For n layers, the total longitudinal unit conductance is

$$S = \sum_{i=1}^n \frac{h_i}{\rho_i} = \frac{h_1}{\rho_1} + \frac{h_2}{\rho_2} + \dots + \frac{h_n}{\rho_n} \tag{6}$$

Total transverse unit resistance is

$$T = \sum_{i=1}^n h_i \rho_i = h_1 \rho_1 + h_2 \rho_2 + \dots + h_n \rho_n \tag{7}$$

Average longitudinal resistivity is

$$\rho_L = \frac{H}{S} = \sum_1^n h_i \div \sum_1^n \frac{h_i}{\rho_i} \tag{8}$$

The average transverse resistivity is

$$\rho_t = \frac{T}{H} = \sum_i^n h_i \rho_i \div \sum_1^n h_i \tag{9}$$

And the anisotropy is

$$\lambda = \left(\frac{\rho_t}{\rho_L} \right)^{\frac{1}{2}} = (TS)^{\frac{1}{2}} \div H \tag{10}$$

The parameters S , T , ρ_L , ρ_t and λ are derived from the consideration of the column of unit square cross sectional area, (1x1 metre) cut of a group of layers of infinite lateral extent (Fig 4). If the current flows vertically only through the column, then the layer in the column will behave as resistance connected in series and the total resistance of the column of unit cross sectional area will be

$$R = R_1 + R_2 + R_3 + \dots + R_n \tag{11}$$

$$R = \rho_1 \frac{h_1}{1 \times 1} + \rho_2 \frac{h_2}{1 \times 1} + \dots + \rho_n \frac{h_n}{1 \times 1} = \sum_i^n \rho_i h_i = T \tag{12}$$

The symbol T is used instead of R to indicate that the resistance is measured in a direction transverse to the bedding and also because the dimension of the unit resistance is usually expressed in Ohm-m² instead of ohm. If the current flows parallel to the bedding, the layers in the column will behave as resistors connected in parallel and the conductance will be

$$S = \frac{1}{R} = \frac{1}{R_1} + \frac{1}{R_2} + \frac{1}{R_3} + \dots + \frac{1}{R_n} \tag{13}$$

$$\text{Or } S = \frac{1 \times h_1}{\rho_1 \times 1} + \frac{1 \times h_2}{\rho_2 \times 1} + \dots + \frac{1 \times h_n}{\rho_n \times 1} = \frac{h_1}{\rho_1} + \frac{h_2}{\rho_2} + \dots + \frac{h_n}{\rho_n} \tag{14}$$

The dimensions of the longitudinal unit conductance are m/Ohm-m = 1/ohm = mho (siemens). It is interesting to note that the quantity $S_i = \frac{h_i}{\rho_i} = \sigma_i h_i$, where σ_i is analogous to transmissivity T_i

= $K_i b_i$ used in ground water hydrology, where k_i is the hydraulic conductivity of the i^{th} layer and b_i is its thickness. The parameters T and S are the ‘‘Dar Zarrouk’’ parameters [14].

In the interpretation of multilayered electrical sounding curves obtained in the area as shown in Fig 5, the evaluation of S and T is sometimes all that can be determined uniquely. The study of the parameters are integral part of the analysis of electrical sounding data and also the basis of important graphical procedures for interpretation of electrical sounding curves [14].

For this study, the secondary parameters are calculated for the first four layers that the maximum current penetration identifies their resistivities and thicknesses. For the fifth layer which has only resistivity but undefined thickness, calculation of secondary parameters was not possible. To calculate the values of the secondary parameter of the aquifers, the average value of the resistivities and thickness were used for each of the layers since it is not possible to have unique value of resistivity and thickness for the aquiferous layer due to inhomogeneity and facies changes [15].

The average values of the primary parameters in each of the layers were used to evaluate the secondary parameters as shown in table 1.

Table1: Aquifer secondary parameter obtained from average value of primary parameters of each of the aquiferous layers

Aquiferous layer number	$\bar{\rho}$ (Ωm)	\bar{h} (m)	$S = h/\rho \times 10^{-3}$ (mho)	$T = hp$ (Ωm^2)	$\rho_L = h/s$ (Ωm)	$\rho_t = T/h$ (Ωm)	$\lambda = (\rho_t/\rho_L)^{1/2}$	Inferred Lithology
1	2031	1.22	0.6	2477.8	2033.3	2031	0.999	medium grained sand
2	2253	8.30	3.7	18716.5	2243.2	2255	1.003	Coarse sand
3	4142	18.28	4.4	75715.7	4154.6	4142	0.998	Very coarse sand
4	5620	42.56	7.6	239187.2	5600.0	5620	1.002	Sand stone

For the four layers the determination of primary parameters was possible, longitudinal conductance S is 0.0163 mho and the total transverse resistance T is 336097.28 Ωm^2 . The average longitudinal resistivity ρ_L is 14031.09 Ωm ; the average transverse resistivity ρ_t is 14048 Ωm and the anisotropy of the layers which theoretically lies between 1 and 2 is approximately 1 as shown in the last column of the table for each of the aquiferous layers.

RESULTS AND DISCUSSION

In this work, the primary parameters which are resistivity and thickness of layers of aquiferous sandy units have been evaluated and compared to the drilled well data as shown in Fig 6. The secondary parameters in table I have been evaluated. A correlation of the experimental result of resistivity has shown goodness of fit with the bore hole data (Fig. 6). This enhances reliability and validity of the secondary parameters most especially the coefficient of anisotropy. The coefficients of anisotropy approximate to unity indicating that the aquiferous layers are all sandy formations with no intrusives, diapir or odd formations that would have made remarkable variations in the transverse and longitudinal resistivities. Fig. 7 obtained using data in Table 1 shows that coefficient of anisotropy is fairly constant with approximately a magnitude of unity. This indicates that there is no variation in the transverse and longitudinal direction of the sandy aquiferous formations in the study area.

Table 1 shows that layers 2,3 and 4 within the maximum electrodes assessed are potentially viable for ground water supply judging from their significant sizeable thicknesses and transverse resistances. Besides, the AKHA, KHA and HKHA curve types represented as a model curve in Fig 5 which are fairly distributed in the study area have good prospects for ground water potential due to low resistivities obtained from H and K curve types. Thus H and K curve types can translate into saturated sand beds of significant yield of water well [16].

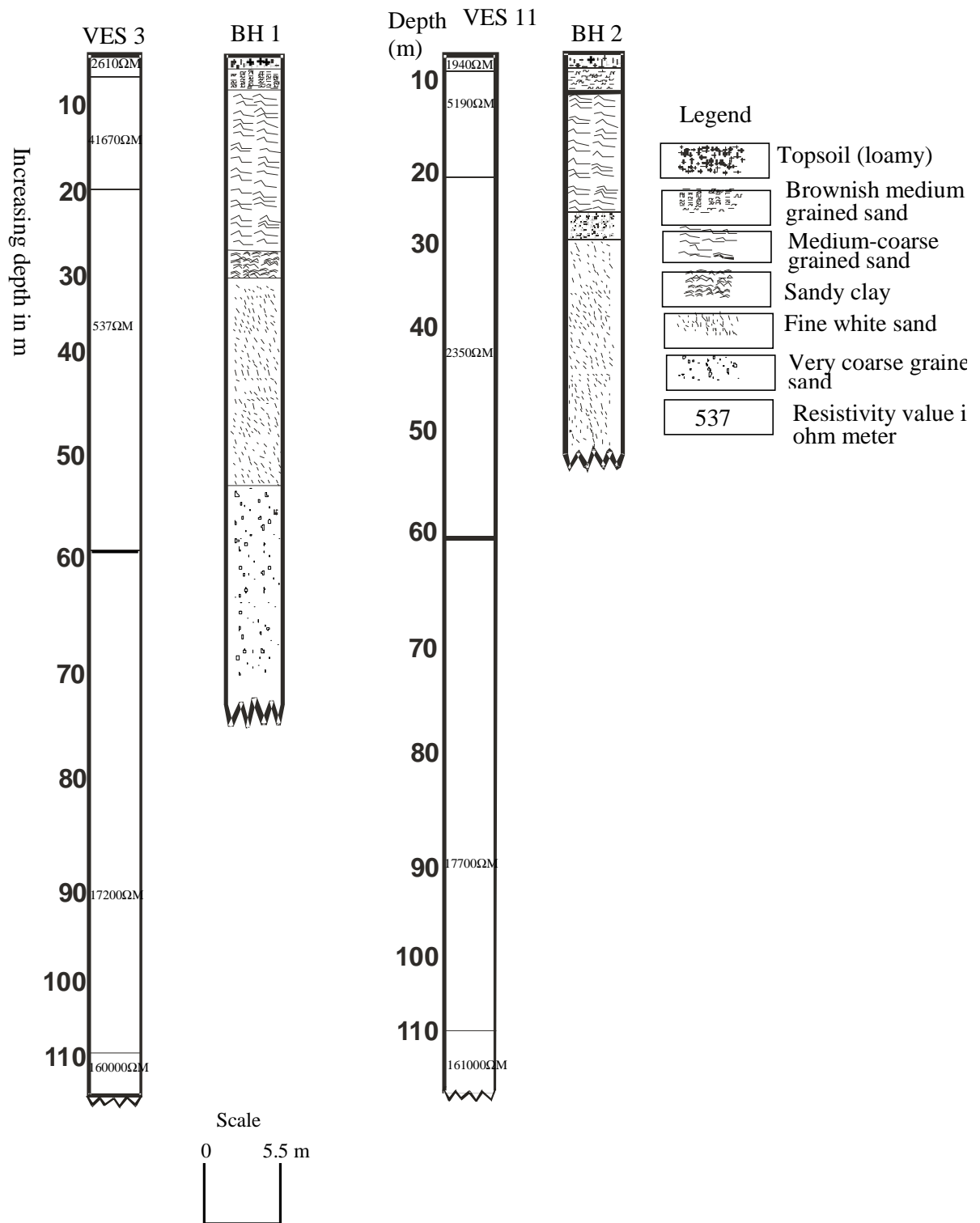

Fig. 6: Correlations of the borehole data with the nearby VES data

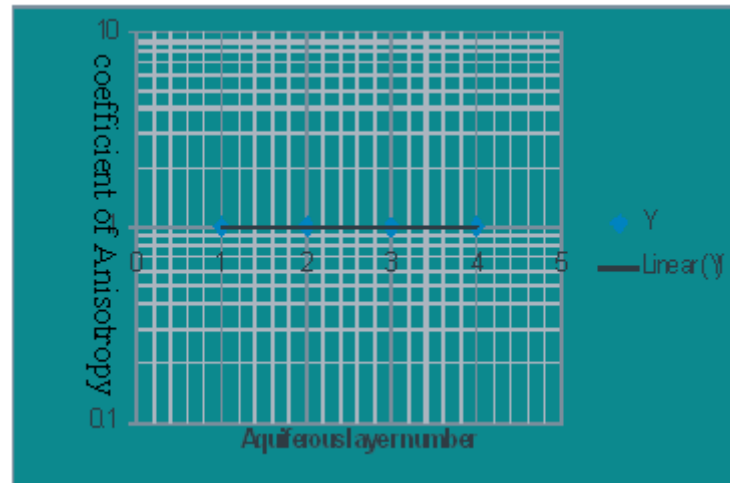

Fig.7: A graph of coefficient of Anisotropy against saturated layer number

According to theory, anisotropy or pseudo-anisotropy is usually 1 or 2 (i.e $1 \geq \lambda \leq 2$) [17]. The coefficient is 1 when the layer is isotropic and is greater than 1 when the layer is anisotropic. The approximate coefficient of 1 obtained for all the layers shows that aquiferous zones are all isotropic and has no directional variation in transverse resistivity with respect to longitudinal resistivity, generally, all the layers in the area surveyed align horizontally with variations in thicknesses caused by changes in facies and lithologic compositions. The static water levels (SWL) of boreholes used for correlation are generally shallow. This is an indication that the water table is very close to the surface and may sometimes be contaminated with surface flows. The horizontally flat layering of the stacked clay-sand sequence has minor hydraulic gradients. The horizontal uniformity and longitudinal arrangements of porous and impermeable clay and porous and permeable coarse sands is the reflection of the unity values of the coefficient of anisotropy. Again, the synergistic effect of the horizontally arranged sandy units as multilayered aquifers also gives rise to the aquifer system that shows anisotropy of unit coefficient.

CONCLUSION

This study shows that parts of southern *Ukanafun* Local Government Area investigated have mainly Continental Plain sands that constitute the productive shallow aquifers. The horizontally aligned clay-sand sequence shows little or no variations in transverse resistance with respect to the longitudinal conductance and this results in the unity of coefficient of anisotropy or pseudo-anisotropy. The shallow nature of the water table encourages the casing of boreholes at depths corresponding to exploitation of water from the first two aquifers which may be contaminated by surface impurities. The formations identified are all sandy and this gives rise to the isotropic nature of the aquiferous units. This study also thrives on evaluating the secondary aquifer parameters such as transverse resistance, longitudinal conductance, transverse resistivity and longitudinal resistivity from primary aquifer parameters which are resistivity and thickness. Although water quality test is needed to ascertain the level of purity or contamination of water, the entire area with isotropic sandy units has good prospects for groundwater that can be tapped in boreholes and open wells at shallow depths. The unity of the coefficients of anisotropy also indicates the absence of intrusives, diapirs and other intrusions of 'foreign' formation of longer wavelengths into the sedimentary formations which averagely have shorter wavelength and higher frequencies sources.

REFERENCES

- [1] George, N. J, Etim O.N, Akpan AE, O. and Obot I. B. *E-J of Chemistry*, India **2010**,7 (3) (in press)
- [2] Evans, U. F, George, N. J, Anthony E. A, Obot, I.B and Akpan, N.I, *E-J.of Chemistry*, India **2010**, 7 (3) (in press)
- [3] Mallany, A. 15th Annual Conference of *Nigeria Journal of Physics*, Karduna, **2004**.
- [4] Igbokwe, M. U, Prakash B. A; Yadaih, P, Kuma, K. M and Chardrasekhar, S.B.N, *National Geophysical Research Institute*, Hyderabad, India, **2004**
- [5] Akpan, F. S, Etim O.N and Akpan A. E, *Nigerian Journal of Physics* 2006, **18** (1), 39-43
- [6] Reijers T. J., A, Peters S. W and Nwajide C. S. The Niger Delta Basin, African Basins, Sedimentary Basins of the world, selly, R.C (e.d) Elsevier, Holland **1997**, p 151
- [7] Edet, A. E, market B.J and Offiong O. E. *Environmental Geology*, **2003**, 44, 137-149.
- [8] Edet A. E. and Okereke C. S. *African Earth's Science*, **2002**, 35, 433.
- [9] Esu, E.O, Okereke C. S. and Edet A.E, *Global Journal of pure and Applied Sciences*, **1999**, 5 (1) 88-96
- [10] Mbonu, D. D. C, Ebiniro J.O, Ofedgbu C. O and Ekine A S. *Geophysics*, **1991**, 56 (2), 234-291.
- [11] Okereke, C. S, Esu, E. O. and Edet A.E. *Journal of African Earth's Science*, **1998**, 27 (1), 149-163
- [12] Zohdy, A. A.R, and Bisdorf R. J, Interpretation programme. *US Geological Survey* **1989**, p.103
- [13] Hemkler, C. J. A. VES Modelling programme for Schlumberger Automatic Analysis resistivity inversion (SAA-V. 92), **1985** 560 pers. comm.
- [14] Zohdy, A. A. R, Eaton, G.P. and Mabey, D.R. Application of Surface Geophysics to Ground water Investigations, Washington, D.C, *U.S Government Printing Office*, **1974**.
- [15] Owoyemi, F.B, Okokie, E.C and Atakpo, E.A, 27th Annual Conference of Nigerian Institute of Physics, Sheraton Hotel and Towers, Abuja, Nigeria, **2002**.
- [16] Sumla, M. and Umego, M. N 27th Annual Conference of Nigerian Institute of Physics Kaduna, Nigeria, **2004**.
- [17] Sundararan, N. Srinivas, Y., Narasimii, M. Chary, Namdakumar, G. and Hanmantha Chary N. Proc. *Indian Academic of Science* (earth planet sc.), **2004**, 113 (3), 259-267.
- [18] Sherieff, R. E, Society of Exploration Geophysics, **1999**.