



Scholars Research Library

Archives of Applied Science Research, 2017, 9 (2):9-15
(<http://scholarsresearchlibrary.com/archive.html>)



Adaptive Neuro-fuzzy System for Determining the Severity Level of Osteomyelitis and Control

Jerome M Gumpy^{1*}, Ibrahim Goni¹ and Umar Timothy Maigari²

¹Department of Computer Science, Adamawa State University, Mubi, Adamawa State, Nigeria

²Department of Computer Science, Federal college of Education (Technical) Gombe Gombe State, Nigeria

ABSTRACT

This research is aimed at developing Neuro-fuzzy system that would determine the severity level of Osteomyelitis (OM) and control. Osteomyelitis is a major disease causing disability and reduction in quality of life. The symptoms of Osteomyelitis were analyzed based on the proper discussion with Experts to gather information about possible symptoms which are used as inputs parameters to the system four (4) inputs were used in this study that is pain, swelling, fever and age with their respective linguistic variables, one hundred and five (105) rules were generated for the system to draw conclusion Neuro-fuzzy methodology and triangular membership function is used throughout this experiment MATLAB 7.0 is used to implement this experiment. This study has paved a way to the creation of intelligent system that would determine the severity level of any kind of disease.

Keywords: Osteomyelitis, Fuzzy logic, Human capabilities, Artificial Neural Network, Neurons

INTRODUCTION

Osteomyelitis is a disease that affects bone and bone marrow but also affect bones of various part of the body, osteomyelitis can be acute or chronic. Once there is osteomyelitis infection it progressively led to softening and necrosis of bones which will be resulted to the formation of sequestra when it reach this stage the only cure for the disease is surgical debridement [1]. Osteomyelitis is a disease caused by the deficiency of Vitamin D among adults which resulted in shortage of calcium salts; bones become very soft and even flexible [2]. It also occurs when newly formed bone matrix failed to undergo mineralization [3]. Vitamin D is one of the key player of mineralization of human skeleton at all ages [4]. Although the major source of this Vitamin D is sunlight that is ultraviolet light [5].

Bone and bone marrow infections are naturally painful and frustrating for both the patients and the doctor, although early diagnosis is the key player to the successful management and cure of the disease [6]. Computational intelligence/ Artificial intelligence and soft computing has been used to solve complex and complicated problems by developing intelligent system more especially in the medical diagnosis [7]. The combination of two or more computational intelligence techniques resulted to hybrids intelligent system which are applied to control engineering, medical diagnosis, cognitive simulations and financial evaluation. [8].

Fuzzy logic

The seed of fuzzy logic was first planted in 1960s by Professor Lotfi A. Zadeh at the University of California, Berkeley, as a way of processing data based on linguistic description. The mathematical foundation of fuzzy logic rest on the shoulder of fuzzy set theory, Fuzzy set theory provides a systematic calculus for dealing with information that is imprecise or incomplete linguistically, and performs numeric computation by using linguistic labels based on chosen membership functions. Fuzzy logic may be regarded as an attempt at formalization of two important human capabilities, first the capability to think and make rational decision in an environment with incomplete information. Second the capability to carryout wide variety of physical and mental task without any dimension or computation.

Fuzzy logic is a superset of conventional logic that has been expanded to handle the concept of partial truth values between the Boolean dichotomy of true and false [9]. Fuzzy logic system is able to simultaneously handle numeric values and linguistic variable. It is also a nonlinear mapping of an input data vector into a scalar output [10].

Neuro-fuzzy

In the field of computational intelligence/ Artificial intelligence and soft computing Neuro-fuzzy is the integration of fuzzy logic and neural network [11]. The fundamental concept of Neuro-fuzzy synergism is derived from a framework called adaptive network known as Adaptive Network-based fuzzy inference system (ANFIS) [12]. This methodology is applied to determine the severity level of osteomyelitis.

An Artificial Neural Network (ANN), is also called a “Neural Network” (NN), is a mathematical model or computational intelligent model based on the concept of biological neural networks, in other words, Artificial Neural Network is a “mathematical representation of the human neural architecture, reflecting its learning and generalization abilities” [13]. A neural network is formed by a series of “neurons” (or “nodes”) that are organized in layers. Each neuron in a layer is connected with each neuron in the next layer through a weighted connection. The structure of a neural network is formed by an input layer, one or more hidden layers, and the output layer one or more. The number of neurons in a layer and the number of layers depends strongly on the complexity of the system studied [13].

MATERIALS AND METHODS

The symptoms of Osteomyelitis were analyzed based on discussion with Experts that suggested possible symptoms which are used as system input parameters. The following are the inputs used in the system, pain, swelling, fever and age. The system inputs parameters are based on patient demographic data and clinical findings obtained during the interviewed with the Medical Expertise. Pain parameter is define based on four (4) linguistic variables as Grade 1, Grade 2, Grade 3 and grade 4, Swelling parameter is define based on five (5) linguistic variables as very Mild, Mild, Moderate, Severe and very severe, Fever parameter are define based on five (5) linguistic variables as very Mild, Mild, Moderate, Severe and very severe, Age are define based on five (5) linguistic variables as Very Young, Young, Middle age, Old, and very Old.

Modeling the Neuro-fuzzy system for the determination of severity level of Osteomyelitis, four distinct input variables are chosen based on the recommendation that Osteomyelitis can be diagnosed using pain and any three other Osteomyelitis symptoms. These input variables are “pain”, “swelling”, “fever” and “age”.

The fuzzification of the inputs provides the degree to which each part of the antecedent has been satisfied for each rule – “belongingness”. Since the antecedent of the rules used in the determination of severity level using fuzzy logic is more than one part, the fuzzy operator “AND” is applied to obtain one number that represents the result of the antecedents for that rule. This number will then be applied to the output function. The input to the fuzzy operator is four membership values from fuzzified input variables. The output is a single truth value. In fuzzy system, every rule has a weight (a number between 0 and 1) which is applied to the number given by the antecedent. However, in the research work, a weight of 1 is assigned to each rule. After assigning the weights to each rule, the implication method is then implemented. A consequent is a fuzzy set represented by a membership function, which weighs appropriately the linguistic characteristics that are attributed to it. The consequent is reshaped using a membership function associated with the antecedent. The input for the implication process is a single number given by the antecedent, and the output is a fuzzy set. Thereafter, implication is implemented for each rule.

System design

The design of the Neuro-fuzzy system that will determine the severity level of Osteomyelitis will be considered under the followings: controller inputs and output, controller linguistic rules, the components of the fuzzy logic controller and the rule base.

I. The Inputs and Output parameters

The choice of the controller’s input(s) and output(s) is a fundamental and vital part of the design since other parts of the design depends on what the inputs and the outputs are.

a. Inputs

The function of the controller is to determine the severity level of Osteomyelitis which can be determined by pain (the major determinant) and any other three of the Osteomyelitis symptoms.

In this work, the researcher made use of pain, which is graded into four grades:

1. Grade 1- when the patient can ignore the pain without taking drugs/pain reliever
2. Grade 2- when the patient can ignore the pain by taking drugs/pain reliever once in a while
3. Grade 3- when the patient can only ignore the pain by consistently taking of drugs/pain reliever (3-4 times daily depending on the prescription)
4. Grade 4- when the patient cannot ignore pain, even while consistently taking drugs.

The other inputs Swelling and Fever use the linguistic variables Very Mild, Mild, Moderate, Severe and Very Severe using triangular Membership function. The last input variable Age uses the linguistic variables Very Young, Young, Middle Age, Old and Very Old.

b. Output

In this research work The Neuro-fuzzy system suggested one output which is the severity level and is define based on two linguistic variables which are High and low.

II. Fuzzification interface

The fuzzification converts the input data namely Pain, Swelling, Fever and Age into suitable linguistic variables. A scale mapping is performed using triangular membership function, which shows the input range variables as corresponding universe of discourse.

b. Knowledge base

The knowledge base consists of database and rule base. The database provides necessary definitions that are used to define linguistic control rules with syntax, such as: IF <fuzzy proportion> THEN <fuzzy proportion>. The 'IF' part is called the 'antecedent' and the 'THEN' part is called the "consequent". The fuzzy IF-THEN rules provide a methodology to represent some objective and/or human knowledge, hence, each rule is a scheme for capturing knowledge that involve imprecision. In this research work - fuzzy-based system for determining the severity level of Osteomyelitis, the antecedents are "pain", 'swelling', 'fever' and 'age' and the consequent is the 'severity level'.

c. Decision making logic

The decision making logic infers a system of rules through the fuzzy operator 'AND' and generates a single truth value which determines the outcome of the rules (inferred fuzzy control action).

d. Defuzzification interface

During fuzzification, the fuzzy input variable, 'Pain' ranging from 1 to 10 will be converted into four linguistic grades namely Grade 1, Grade 2, Grade 3 and Grade 4. Similarly, the input variable 'Age' will be converted into five linguistic variables namely: Very Young, Young, Middle Age, Old and Very Old.

The other two fuzzy input variables; 'Swelling' and 'Fever' and the output variable 'Severity Level' ranging from 1 to 10 are converted into five linguistic levels namely: Very Mild, Mild, Moderate, Severe and Very Severe. The triangular membership function is used to perform the scale mapping.

III. Rule base

The behavior of the control surfaces is defined by the rules that join the fuzzy variables together. In this work, 500 rules will be framed with the assistant of an Orthopedics. All the rules will be presented in the form of a rule base matrix, where the antecedents are the 'Pain', 'Swelling', 'Age' and 'Fever' and the consequent of the rules is 'Severity Level'.

Input membership functions of the experiment

1. Pain membership function

Pain is defined based on four linguistic variables, which are Grade 1, Grade 2, Grade 3 and Grade 4. In which grade 1 has the lowest severity level and grade 4 has the highest severity level as shown in the Figure 1 below.

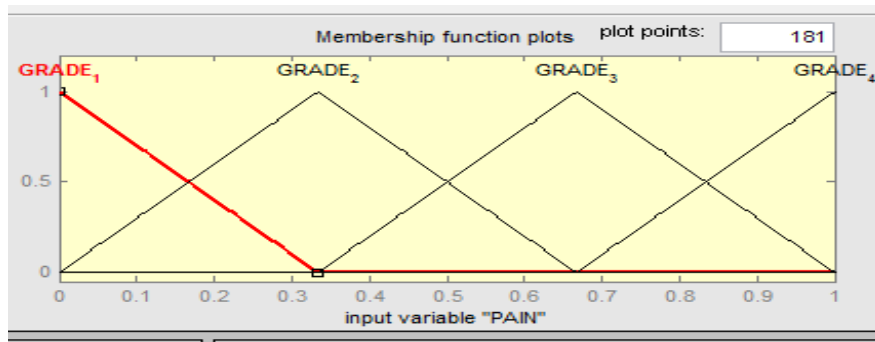

Figure 1: Membership function of pain.

2. Swelling membership function

Swelling is defined based on five linguistic variables which are very mild, mild, moderate, severe and very severe as shown in the Figure 2 below.

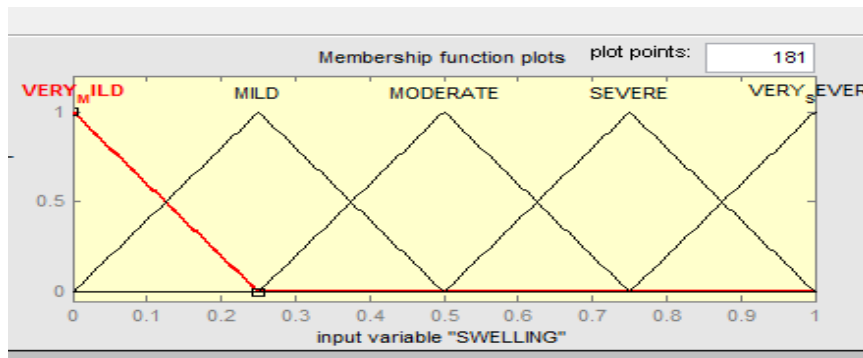

Figure 2: Membership function of swelling.

3. Fever membership function

Fever is defined based on five linguistic variables which are very mild, mild, moderate, severe and very severe as shown in the Figure 3 below.

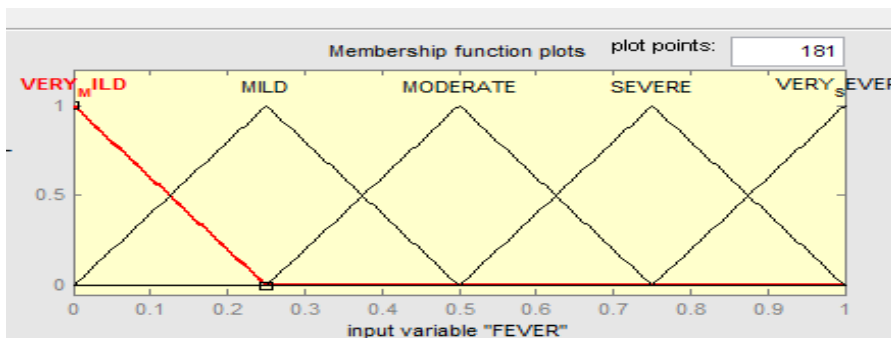

Figure 3: Membership function of fever.

4. Age membership function

Swelling is defined based on five linguistic variables which are very young, young, moderate age, old and very old as shown in the Figure 4 below.

The effect of ‘pain’ is plotted against another variable ‘swelling’ in Figure 5, it can be seen that the higher the pain and swelling, the higher the severity level (severity level) of the system. The model takes into cognizance factors like fever and age. Peak requirement for high severity level is when both the pain and the swelling are ‘very severe’. In Figure

6 below the system combines adequately factors like ‘pain’, ‘fever’ and ‘age’ amongst other and present the fuzzified results in the level of severity. The presented simulated results are in three-dimensions. This is because presently it is difficult to represent higher dimensions without distorting the Figures 7-9 in MATLAB tools. This has limited the number of variables to be considered to two against the fixed variable (output). It has not in any way however hindered the functionality of the system because each factor represented is depicted as an integral part of the whole system whose variables has been fuzzified.

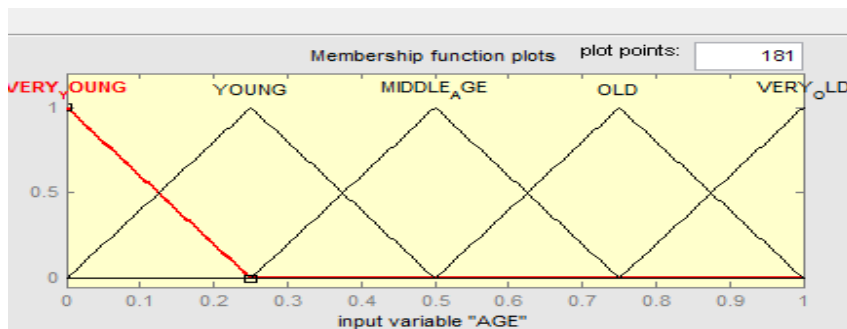

Figure 4: Membership function of age.

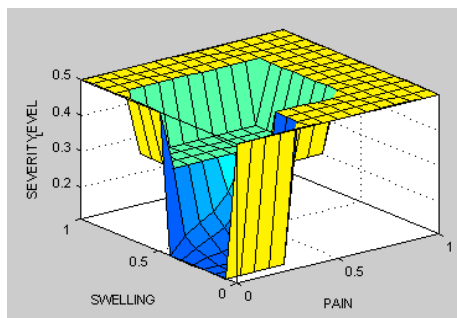

Figure 5: Swelling and pain against severity level.

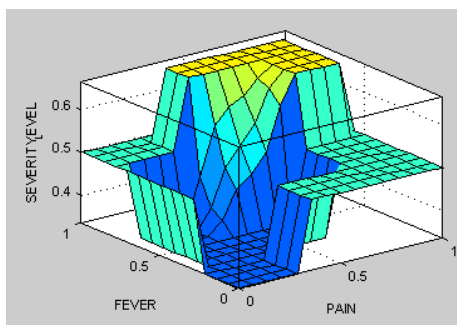

Figure 6: Fever and pain against severity level.

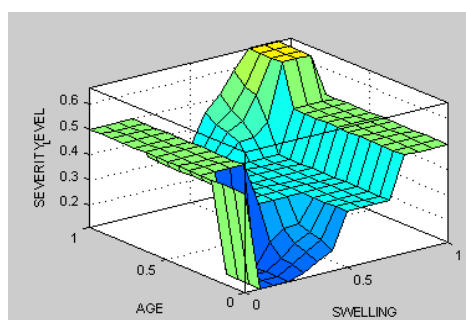

Figure 7: Age and swelling against severity level.

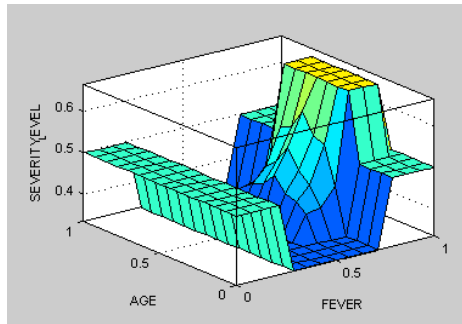

Figure 8: Age and fever against severity level.

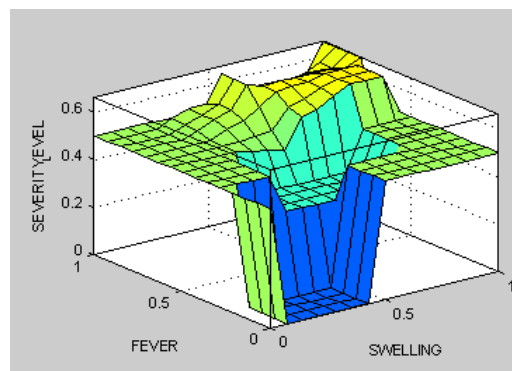

Figure 9: Fever and swelling against severity level.

Another factor considered in the course of the research is the effect of natural phenomenon like age. It is unfortunate that Osteomyelitis is common among older adult, and since the goal of this work is to determine the severity level of Osteomyelitis in children and adult, a specific age range (50 – 75) is specified for the input variable ‘age’. The peak of this appeared only when pain is in Grade 4 and age is above 60 years as shown in Figure 7.

Neuro-fuzzy Model

The Figure 10 below shows how the four inputs that is pain, swelling, fever and age are mapped to their linguistic variables of which the pain has four (4), swelling has five, fever has five and age has five linguistic variables and these also mapped to the 105 rules generated the rules also mapped to the linguistic variables of the output and finally produced a severity level of Osteomyelitis.

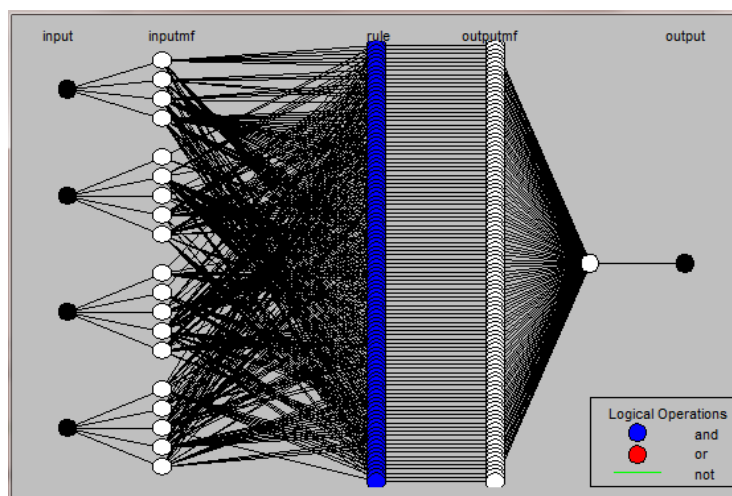

Figure 10: Neuro-fuzzy model for determine the severity level of Osteomyelitis.

CONCLUSION

This research work presented a Neuro-fuzzy system designed that determined the severity level based on identified factors (input variables). Osteomyelitis affects mobility, but if diagnosed on time, it can be managed. With fuzzy based system, severity level can be determined and the ailment properly managed based on the usage of linguistic variables and the membership function developed for them. As opposed to expert systems, fuzzy system employs linguistic variables which facilitate human description using their natural language. With this development, Osteomyelitis symptoms only need to be inputted in natural language term and not precise values. The results are entrusting and promising based on the flexibility and case of adaptability.

REFERENCES

- [1] Eid, A.J., and Barbari E.F., Osteomyelitis: Review of pathophysiology, diagnostic modalities and therapeutic options. *J. Med Liban*, **2012**. 60(1): pp: 51-60.
- [2] Tim, C., *Osteomalacia and Rickets*, **2011**.
- [3] Ceyhun, V., et al., A case of osteomalacia initially followed as restless leg syndrome for 6 months. *Biomedical Research*, **2016**. 27(4): pp: 1284-1287.
- [4] Al-Ali, H., and El-Hajj Fuleihan, G., Nutritional Osteomalacia, *Journal of Clinical Densitometry*, **2000**. 3(1): pp: 97-101.
- [5] Morgan, D.B., Osteomalacia and osteoporosis, *Postgraduate medicine Journal*. **1968**. 44: pp: 621-625.
- [6] Daniel, P.L., and Francis, A.W., Osteomyelitis Seminar Service of Infectious Diseases, **2004**.
- [7] Phuong, Nguyen Hoang, and Kreinovich Vladik, "Fuzzy Logic and its Applications in Medicine" *Departmental Technical Reports (CS)*, **2000**. pp: 498.
- [8] Robert, F., Neuro-fuzzy methods. **2001**.
- [9] Ibrahim, G., and Ahmed, L., A propose neuro-Fuzzy-genetic intrusion detection system. *International Journal of Computer Applications (0975 – 8887)*, **2015**. 15(8).
- [10] Hoang, C., Thuan, N., and Trung, L., Neuro-fuzzy approach to heart rate variability analysis. *International Journal of Bioscience, Biochemistry and Bioinformatics*, **2013**. 3(5): pp: 456-459.
- [11] Jyh-shing, R. J., and Chuen, T. S., Neuro-fuzzy modeling and control; IEEE **1995**.
- [12] Amato, F., et al., Artificial Neural Networks in medical diagnosis *Journal of Applied Biomedicine* **2013**. 11: pp: 47-58.
- [13] Ibrahim, G., Ahmed, L., and Jerome, M.G., Designing a fuzzy rule based system to predict students academic performance in Adamawa State University Mubi. **2015**.